

hidroconta
metering technology

WHEN WATER COUNTS



water meter

hidroJet

hidroconta.com



Multi jet
technology

approval
EMEÑE

Magnetic
transmission

Convertible into a
Smart meter

High accuracy
R80H

Pre-equipped for
pulse emitter

Installation
UO/DO

REV3

Hydrodynamic design

The multi-jet technology ensures uniform load distribution over the turbine thanks to the diffuser located at the water inlet. The movement activates the magnetic transmission which will give the final volume reading.

EMEÑE approval

Thanks to the acquired homologation, the low maintenance requirements and the low pressure losses, this product is suitable for the totalisation of water in hydraulic networks for irrigation and public water use.

Technical specifications

- ✓ - Turbine and dial in thermoplastic material.
- ✓ - Clockwork assembly under vacuum to prevent water condensation.
- ✓ -Magnetic transmission protected against external magnetic fields.
- ✓ - Pre-equipped with pulse emitter for remote reading. Quick connection without stopping or disassembling the water meter.
- ✓ - High mechanical and wear resistance.
- ✓ - Accuracy ratio R80 in horizontal and R40 in vertical position.
- ✓ - No need straight sections at the inlet or outlet of the water meter.

Pre-equipped

The dial of the water meter has a pre-installation that allows the installation of a pulse emitter, without the need to stop the water meter, this will give information about the reading.

High protection

Hidroconta's Hidrojet water meters are designed to avoid external manipulation by magnetic fields. They have a special shielding that covers the dial, which prevents any possible fraud in the transmission and therefore in the result of the reading.

Dial

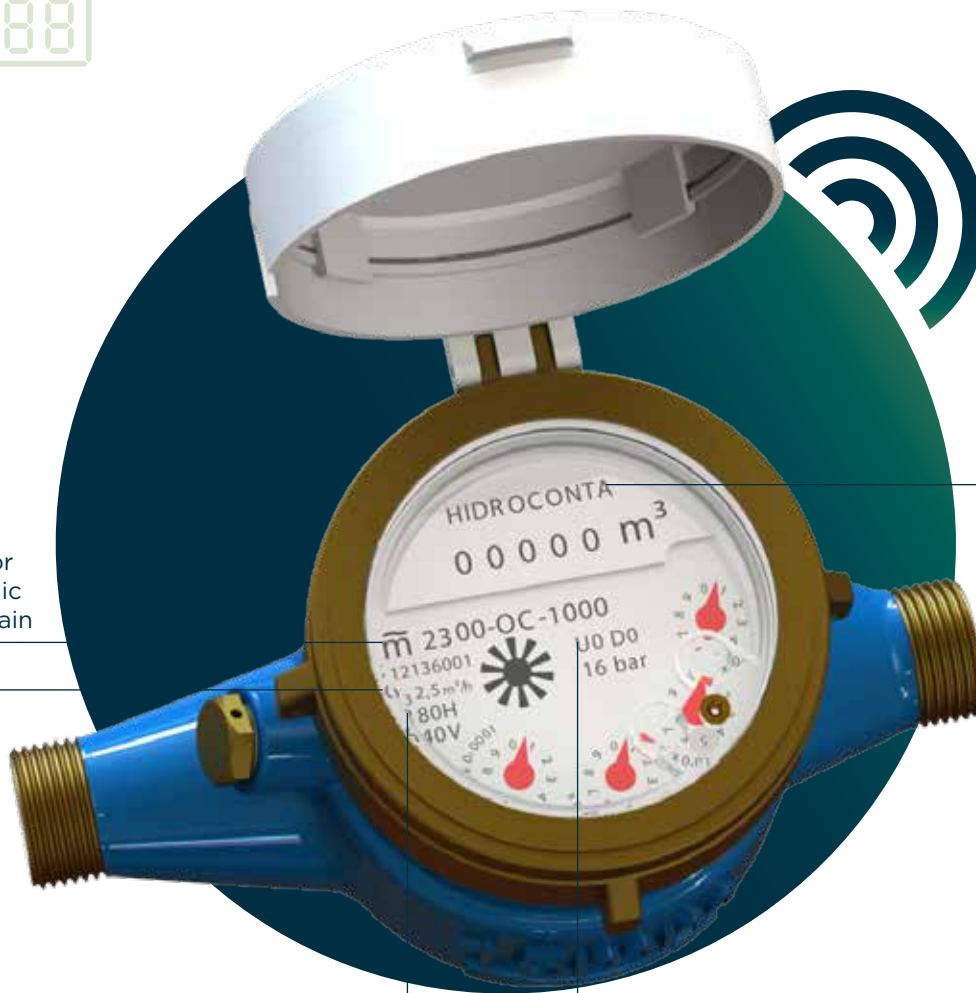

Emeñe approval for use of public water domain

Permanent flow rate

Horizontal working range
 Vertical working range

Installation conditions
 Maximum working pressure

Manufacturer's name

Disassembly



Nº	DESCRIPTION	MATERIAL
1	Body	Grey cast iron / composite
2	Inlet filter	Plastic
3	Regulation screw seal	Plastic
4	Adjusting screw	Brass
5	Seal	Silicone
6	Low chamber filter	Plastic
7	Lower chamber	Assembly
8	Propeller	Plastic
9	Flat seal	Silicone
10	Watch	Assembly
11	Upper ring	Plastic
12	Cover shaft	Brass
13	Upper ring	Brass
14	Top cover	Plastic

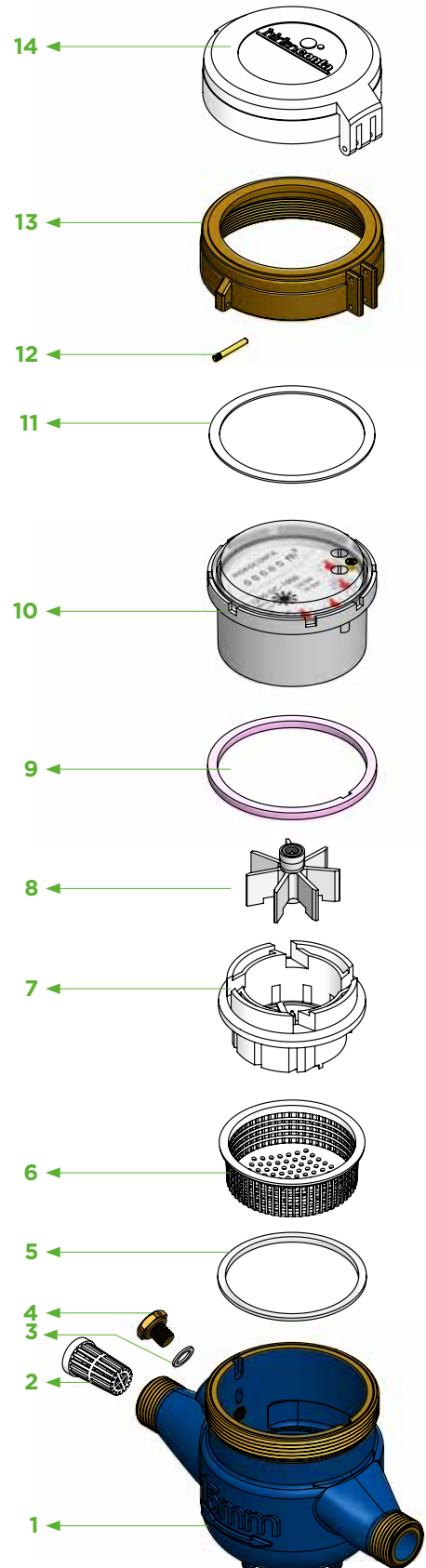

Dimensions

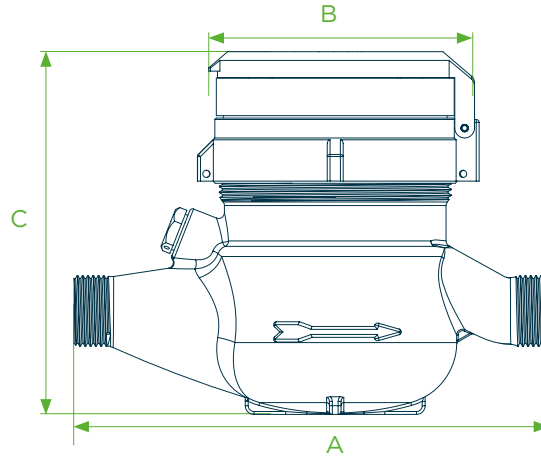

CALIBRE		A	A (with fittings)	B	C	WEIGHT WITH FITTINGS	WEIGHT WITHOUT FITTINGS	THREADED CONNECTIONS	MATERIAL
mm	in	mm			Kg				
15	1/2"	165	260	94	125	1,34	1,17	G 3/4"	Grey cast iron
		165	260	94	130	0,63	0,58		Composite
20	3/4"	195	286	94	125	1,56	1,36	G 1"	Grey cast iron
		195	295	94	130	0,71	0,62		Composite
25	1"	260	375	100	135	2,59	2,18	G 1-1/4"	Grey cast iron
		225	345	110	135	1,00	0,84		Composite
32	1-1/4"	260	385	100	135	2,95	2,34	G 1-1/2"	Grey cast iron
		230	352	110	135	1,18	0,93		Composite
40	1-1/2"	300	430	125	170	5,48	4,66	G 2"	Grey cast iron
		245	375	125	180	1,75	1,46		Composite
50	2"	300	450	125	170	6,86	5,10	G 2-1/2"	Grey cast iron

Packing

DIAMETER		PCS. PER BOX	DIMENSIONS PER BOX (CM)			GROSS WEIGHT (cast iron water meter)	GROSS WEIGHT (composite water meter)
mm	in		Length	Width	Height	Kg	
15	1/2"	1	20	10	13,5	1,35	0,62
		10	50	22	29	13,00	-
20	3/4"	1	20	10	13,5	1,49	0,72
		10	50	22	29	15,00	6,50
25	1"	1	27	14	13	2,64	1,02
		5	71	30	14	13,50	5,60
32	1-1/4"	1	27,5	14,5	12,5	3,03	1,14
		5	71	30	14,5	14,5	5,60
40	1-1/2"	1	31,5	19,5	13,5	5,45	1,76
		2	33	22	30,5	11,20	3,80
50	2"	1	31,5	20	14	6,93	-
		2	33	22	30,5	13,50	-

Working conditions

WATER TEMPERATURE RANGE

0,1 °C - 30 °C

MAXIMUM PRESSURE

≤ 16 bar

For cast iron body

≤ 10 bar

For composite body

Maximum permissible error

RANGE

ERROR (%)

$Q_1 \leq Q < Q_2$

± 5%

$Q_2 \leq Q \leq Q_4$

± 2%

Technical specifications

CALIBRE		Q ₄	Q ₃	Q ₂	Q ₁	MINIMUM READING	MAXIMUM READING	RATIO
mm	in	m ³ /h				m ³		
15	1/2"	3,12	2,50	0,05	0,03	0,05	99.999	R80H
				0,10	0,06			R40V
20	3/4"	5,00	4,00	0,08	0,05	0,05	99.999	R80H
				0,16	0,10			R40V
25	1"	7,87	6,30	0,13	0,08	0,05	99.999	R80H
				0,25	0,16			R40V
32	1-1/4"	12,50	10,00	0,20	0,13	0,05	99.999	R80H
				0,40	0,25			R40V
40	1-1/2"	20,00	16,00	0,32	0,20	0,05	99.999	R80H
				0,64	0,40			R40V
50	2"	31,25	25,00	0,50	0,31	0,05	99.999	R80H
				1,00	0,63			R40V

Pressure loss curve

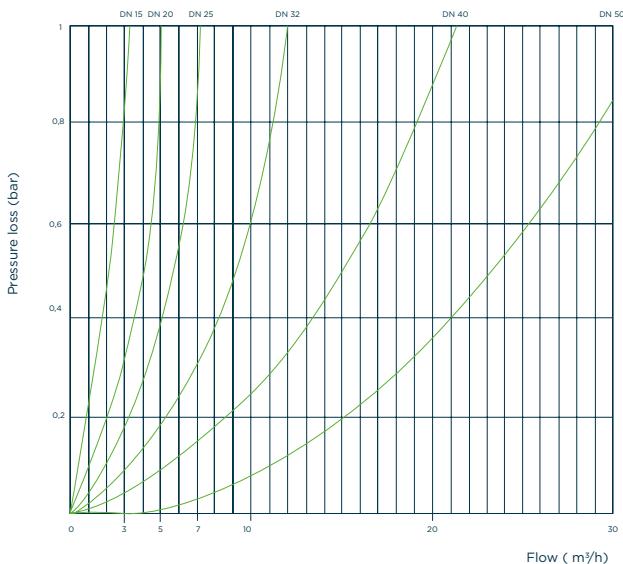

Flow error curve

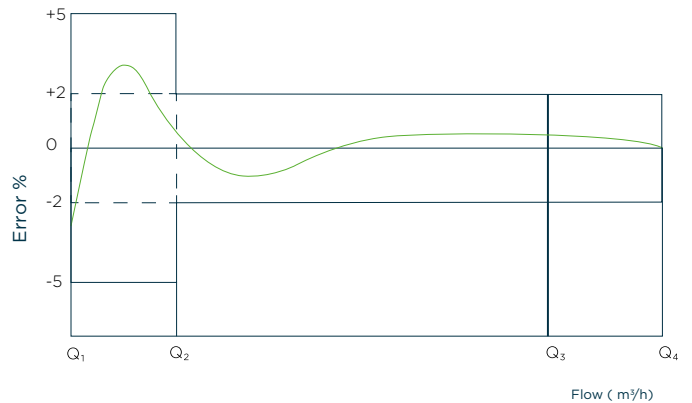

Pulse output



REED SENSOR

Pulse value	1 pulse 100L
Minimum current for contact closure	0mA
Maximum contact closing current	100mA
Contact closed resistance	< 1 Ω
Open contact resistance	~ ∞
Max. withstand voltage	24V
Max. contact stabilisation time	100 us
Contact closed contact duration	40% of cycle
Standard cable length	1,5 m

Installation diagrams

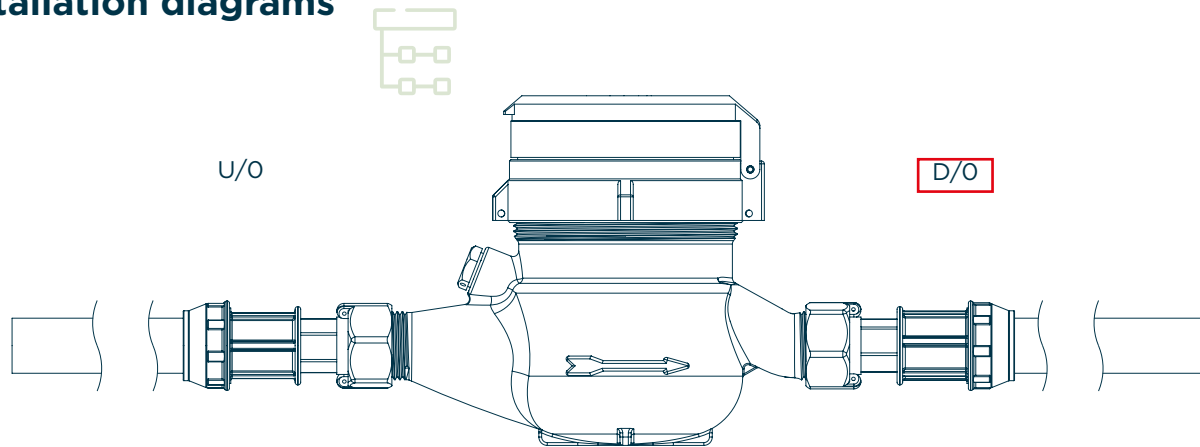

Installation instructions

It is recommended to always place the water meter at a low point in the installation.

Position the water meter so that the arrow corresponds to the direction of water flow.

Do not force the water meter during installation, avoid tensile and torsional stresses.

Water meters must always be filled with water. A minimum pressure of 0.3 bar is recommended at the outlet of the water meter to ensure that it is filled with water. Install at a lower level concerning the slope of the rest of the pipe, this will also eliminate the formation of bubbles inside the pipe.

If air is present in the pipe, it is necessary to install air release valves to avoid erroneous readings. If the water in the pipe has coarse particles in suspension, it is recommended to install a roughing filter beforehand.

Provide a shut-off valve upstream of the water meter to facilitate maintenance and/or repair.

Before installing a water meter in a new pipe, it is recommended to empty the pipe to remove particles.

The inside diameter of the pipe should be equal to the nominal diameter of the water meter.

It is not necessary to install straight sections before or after the water meter UO-DO.

Suitable for installation in horizontal position R80H and vertical position R40V.

Automatic meter reading

Adding the IRIS communications module to the water meter will enable automatic remote readings. IRIS devices allow mechanical meters to access the world of IoT communications. Its great versatility allows it to be integrated with a wide range of meters.

The IRIS communications module is integrated with the Demeter system. It supports the integration of a wide range of devices using various communication technologies to suit the needs of the installation.

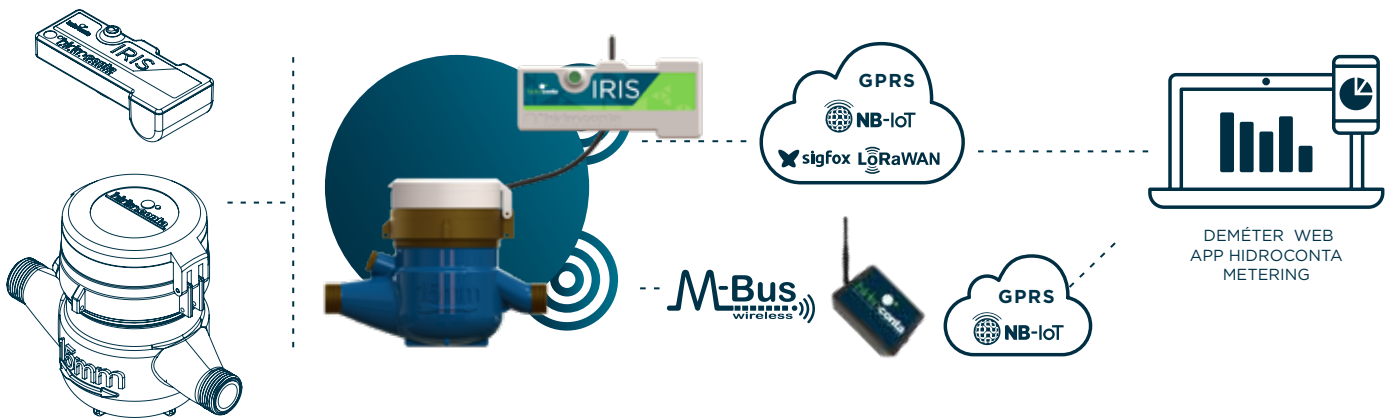

NB-IoT

Belts	LTE NB2/B1/B2/B3/B3/B4/B5/B8/ B12/B13/ B17/B18/B19/ B20/B25/B28/B66/ B70/B85
Transmission power	23 dBm +/-2dB
Firmware Update	Via FOTA

M-Bus wireless

868 MHz

OMS T1 and C1

GPRS

Frequency	<ul style="list-style-type: none"> - Quad-band: GSM850, ESM900, DCS1800, PCS1900. - The module can search for these frequency bands automatically. - The frequency bands can be configured by AT command. - GSM Phase 2/2+ compliant
Transmission power	Class 4 (2W) on GSM850 and EGSM900 Class 1 (1 W) on DCS 1800 and PCS1900
Bidirectional	Yes/Half-duplex
SIM	MFF2 eSIM and nano SIM card supported

LoRaWAN

Modulation	CSS	CSS
Frequency	EU868* ISM band	ISM band US915, AU915, AS923**/ ***
Power	14 dBm	20 dBm
Sensitivity	168 dBm	168 dBm
Bandwidth	125 kHz	125 kHz
LoRaWAN Configuration	SF12	SF12
Bidirectional	Yes/Half-duplex	Yes/Half-duplex
Encryption	AES128	AES128
Standardisation	LoRa-Alliance	LoRa-Alliance

sigfox

Geographical availability	RC1*	RC2**	RC4***
Modulation	BPSK	BPSK	BPSK
Frequency	Tx Freq. : 868.13MHz Rx Freq. : 869.525MHz	Tx Freq. : 902.2MHz Rx Freq. : 905.2MHz	Tx Freq. : 920.8MHz Rx Freq. : 922.3MHz
Power	14 dBm (max) @600bps	+24dBm (max.) @600bps	+24dBm (max.) @600bps
Sensitivity	-127dBm @600bps	-129dBm(min.) @600bps	-129dBm(min.) @600bps
Bandwidth	100 Hz	100 Hz	100 Hz
Bidirectional	Limited/Half-duplex	Limited/Half-duplex	Limited/Half-duplex



Alarms

🔔 Leakage alarm:

Detection of continuous consumption for a maximum period of time. Configuration adjusted by communications.

🔔 Water meter stopped alarm:

The alarm is activated if no consumption is detected for a maximum period of time. Configuration adjusted by communications.

🔔 Under-dimensioned water meter alarm:

Detection of flow rate higher than the overload flow rate for a maximum period of time. Configuration adjusted by communications.

🔔 Battery status alarm:

Various battery alarm levels are activated depending on the remaining battery life.

REV3

Functionality



Operating profiles based on the recording consumption and communications records requirements:

- Normal-24: Sending data every 24 hours and recording every hour.
- Normal-8: Sending data every 8 hours and recording every hour.
- Medium: Sending data every 12 hours and recording every 30 minutes.
- Extreme: Sending data every 6 hours and recording every 15 minutes.

MODE	AUTONOMY	COMUNICACION	DATA HISTORY RECORD
Normal -24	12 years	24 h	1 h
Normal -8	TBD	8 h	1 h
Medium	TBD	12 h	30 min
Extreme	TBD	6 h	15 min

* TBD (to be determined). 24 maximum storage and sending readings: each sending allows accumulating up to 24 values for each communication interval.

8



1. Which is the difference between dry dial, wet dial and semi-dry water meter dial?

On water meters with dry dial the reading mechanism (clock) is tightly separated from the wet chamber of the meter.

On Wet dial water meter the watch is totally immersed in the fluid.

For water meters with semi-dry dial, the reading mechanism is totally immersed in the fluid but the dial is partially separated and protected by a sealed capsule.

2. What are the ranges of measurement and precision?

The measuring range of the meters is determined by the Directive MID 2014/32 / UE establishing the ratio between the value of the permanent flow (Q3) and that of the minimum flow (Q1). The water meter can measure up to the maximum flow rate (Q4) for short periods of time without deterioration.

The maximum permissible error, positive or negative, in volumes between the transition flow (Q2) (included) and the overload flow (Q4) would be 2% with a water temperature 30 ° C.

The maximum permissible error, positive or negative, in volumes between the minimum flow rate (Q1) and the transition flow (Q2) (excluded) would be 5%.

3. The MID directive and its compliance

The MID Directive (2014/32 / EU Measuring Instruments Directive) is a directive of the European Union whose purpose is to harmonize the different aspects of Legal Metrology in the member states.

The most important aspect of this directive is that equipment in possession of a MID certificate can be used in the EU.

hidroconta
metering technology

WHEN WATER COUNTS

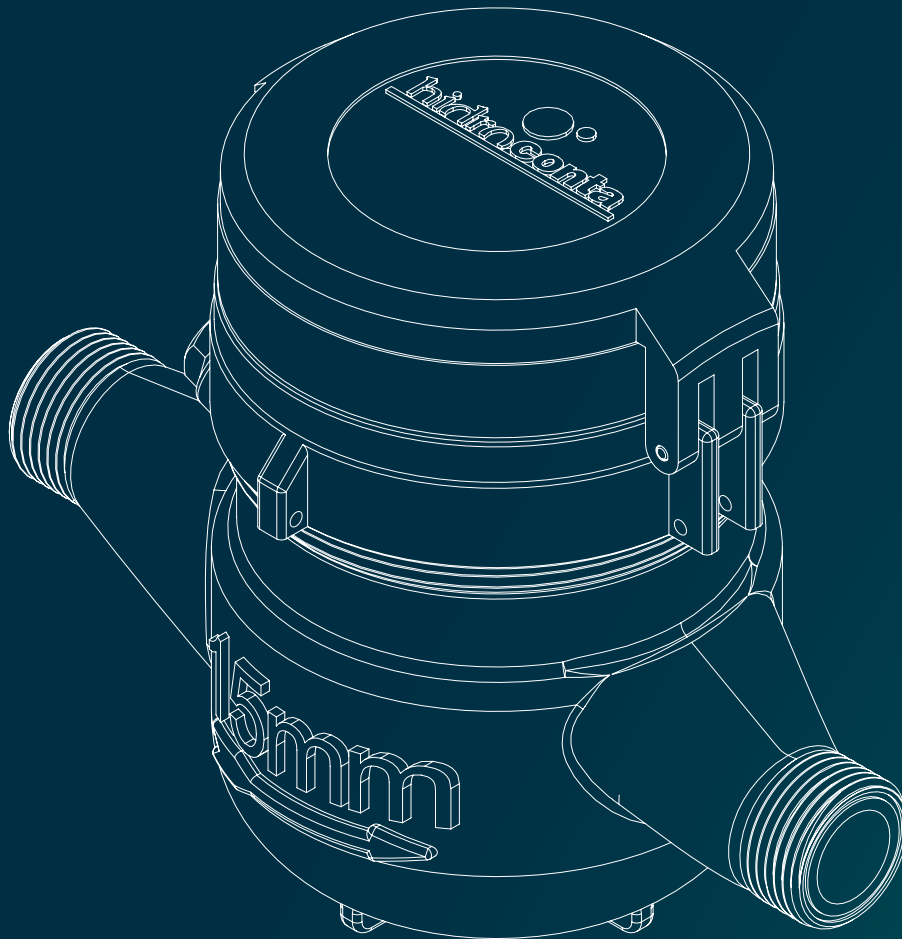

water meter

hidroJet

Ctra. Sta Catalina, 60
Murcia (30012) España
T: +34 968 26 77 88



ER-0362/2000



Hidroconta se exime de responsabilidad respecto a errores de la información expuesta en este documento, la cual podrá ser modificada sin previo aviso. Todos los derechos están reservados.
© Copyright. 2023 HIDROCONTA. S.A.U.

[hidroconta.com](https://www.hidroconta.com)